

PROFILI PER SERRAMENTI ELETTROSALDATI

SERIE m/m 28

11A – Spessore 15/10 = kg/ml 1,34

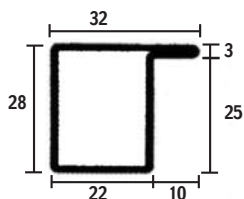

SERIE m/m 38

1A – Spessore 15/10 = kg/ml 1,72

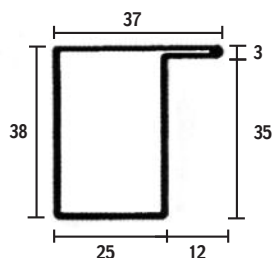

11B – Spessore 15/10 = kg/ml 1,57

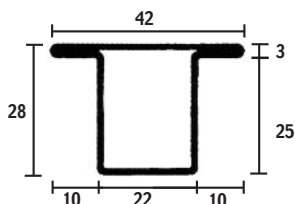

1B – Spessore 15/10 = kg/ml 2,10

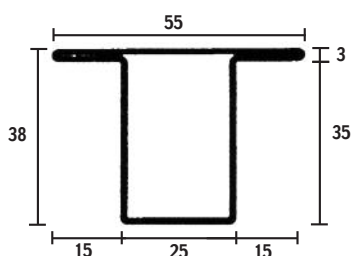

11C – Spessore 15/10 = kg/ml 1,57

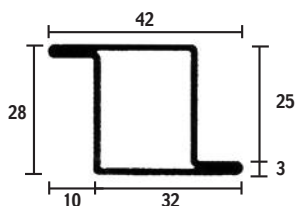

1C – Spessore 15/10 = kg/ml 2,00

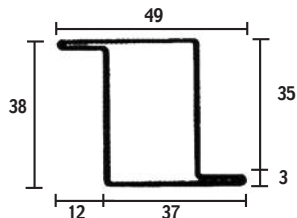

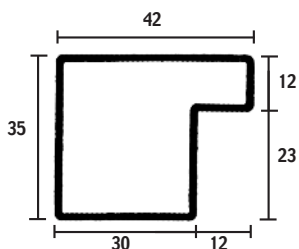
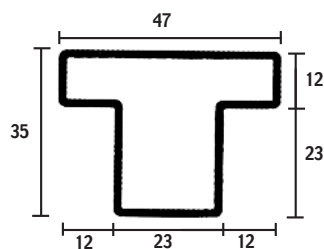
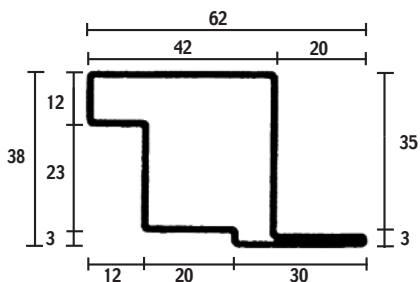
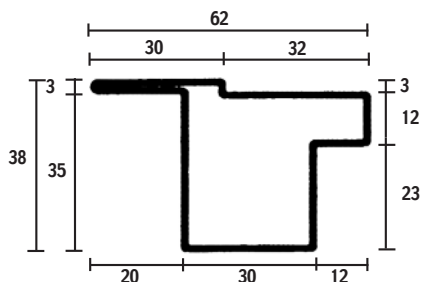
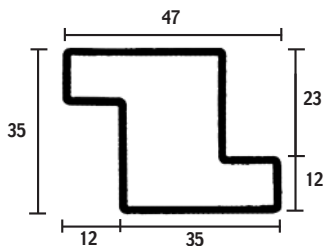
SERIE m/m 35**2A – Spessore 15/10 = Peso kg/ml****2B – Spessore 15/10 = kg/ml 1,88****2N – Spessore 15/10 = kg/ml 2,30****2T – Spessore 15/10 = kg/ml 2,30****2Z – Spessore 15/10 = kg/ml 1,88**

SERIE m/m 50

16A – Spessore 15/10 = kg/ml 2,3

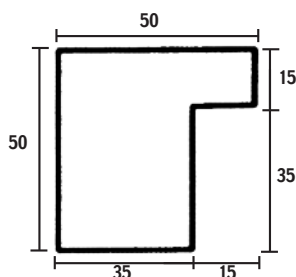

16D – Spessore 15/10 = kg/ml 4,65

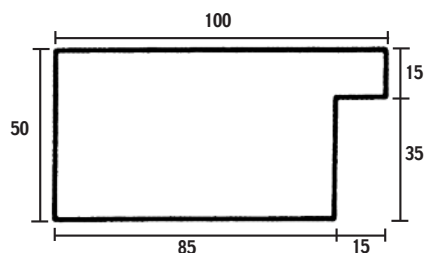

16B – Spessore 15/10 = kg/ml 2,3

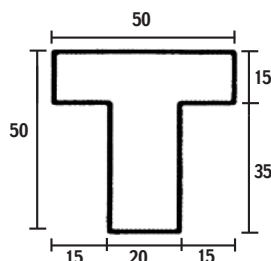

16Z – Spessore 15/10 = kg/ml 2,55

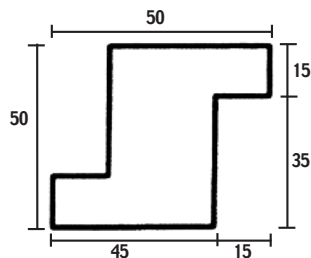

FERMAVETRO AD “U” E FERMAVETRO TUBOLARI SERIE TR

Fermavetro ad “U”

TR1



TR4

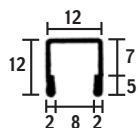

Regolini a scatto

TR3

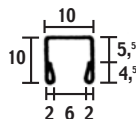

TR8

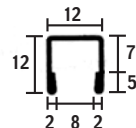

SERIE 15

15A – Spessore 15/10 = kg/ml 2,04

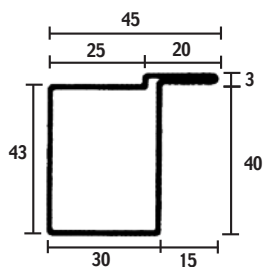

SERIE SF

1B – Spessore 15/10 = kg/ml 2,15

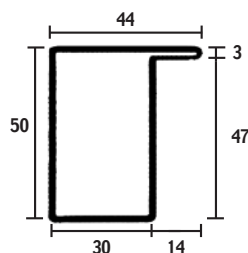

15T – Spessore 15/10 = kg/ml 2,45

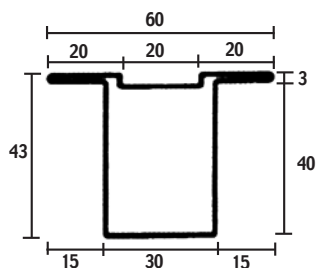

2B – Spessore 15/10 = kg/ml 2,52

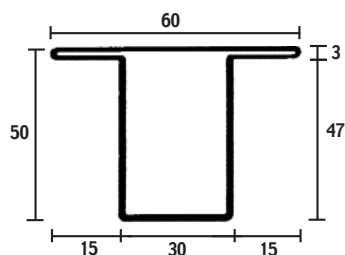

15Z – Spessore 15/10 = kg/ml 2,45

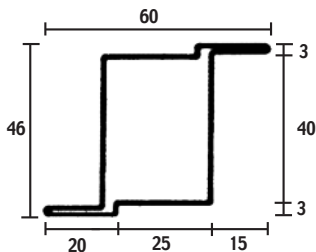

3B – Spessore 15/10 = kg/ml 2,52

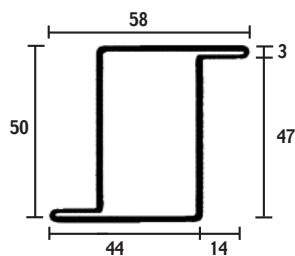

SERIE 21

TS21L – Spessore 15/10 = kg/ml 2,05

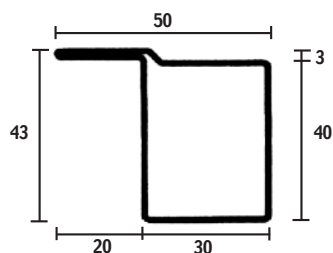

SERIE 20

TS20L – Spessore 15/10 = kg/ml 3.330

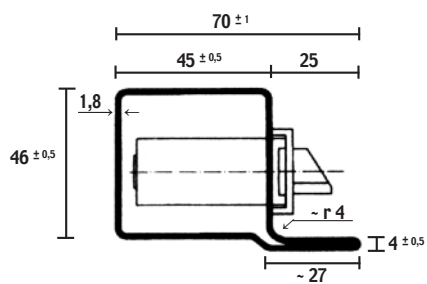

TS21T – Spessore 15/10 = kg/ml 2,64

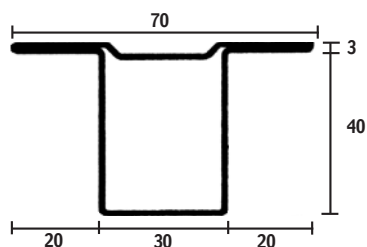

TS20T – Spessore 15/10 = kg/ml 4.000

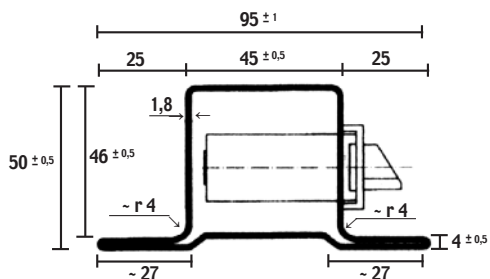

TS21Z – Spessore 15/10 = kg/ml 2,64

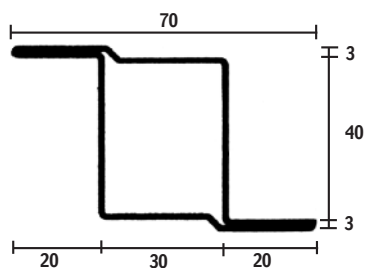

TS20Z – Spessore 15/10 = kg/ml 4.000

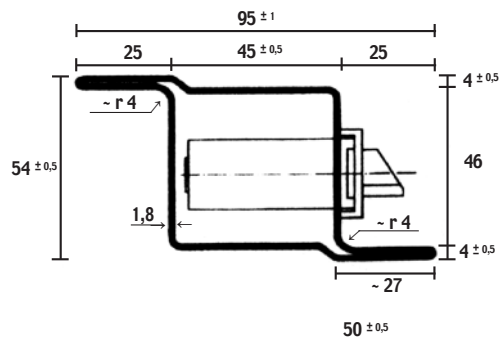

SERIE PS

PSZ- Spessore 15/10 = kg/ml 2,34

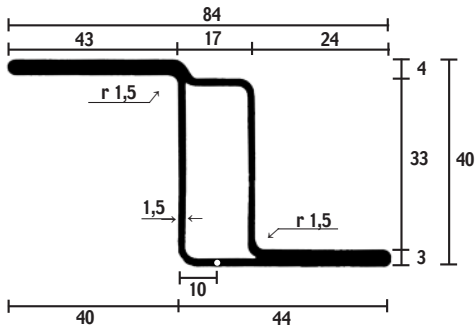

PSB- Spessore 15/10 = kg/ml 3,00

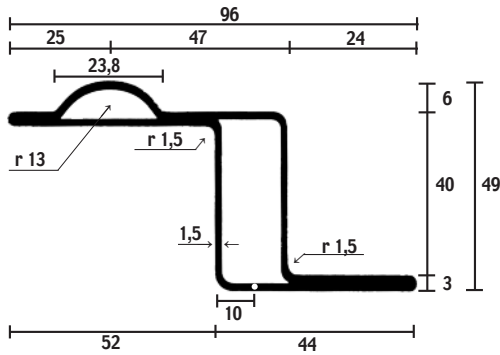

PSL - Spessore 15/10 = kg/ml 2,66



TAVOLA 1846

Spessore 15/10 = kg/ml 2,75

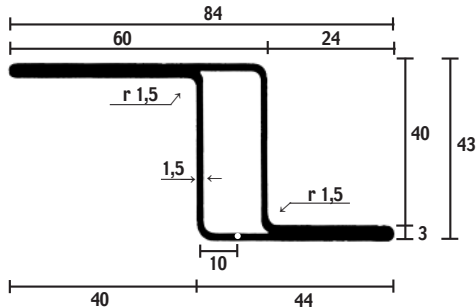
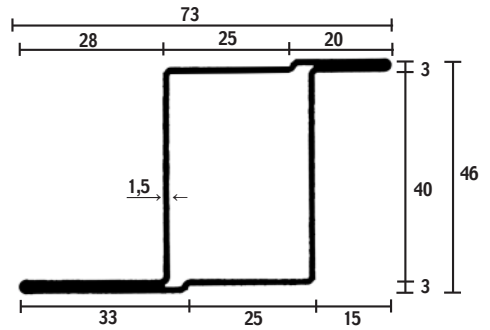

PROFILI PER TELAIO

T2121- Spessore 15/10 = kg/ml 2,75



TAVOLA 1776

Guida

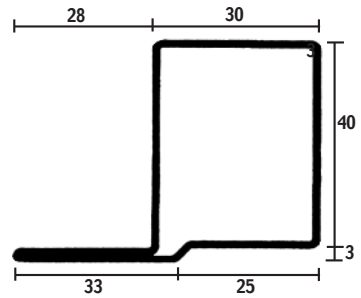